



TG-1 *Express*

Installation Guide



COMPANY CONFIDENTIAL
For use by TELGUARD® customers only.
Distribution to other parties strictly prohibited.



February 27, 2010

Important Note

The registration form must be completed before leaving for the job site to install the Telguard product. There are four ways to register a Telguard unit:

- register online at www.telguardonline.com,
- send the electronic registration form at www.telular.com/telguard,
- email the completed registration form to cellservice@telular.com, or
- fax the completed registration form to 678-945-1651.

Foreword

The Telguard model TG-1 Express cellular alarm communicator (p/n TG1GX001) is UL Listed for Household Fire systems and Household Burglary systems. This means that the TG-1 Express may be used in Household Burglary systems, Household Fire systems or combined Household Burglary & Fire system as the primary communication path.

Technical Support

Technical support for all Telguard products is available Monday through Saturday.

Toll Free: 800-229-2326, option **9**
Monday -Saturday 8am -8pm EST

About this Manual

This manual assumes that you have basic security system installation skills such as measuring voltages, stripping wire, properly connecting wires together, connecting wires to terminals, and checking phone lines. It also assumes that you have a familiarity with the proper installation and programming tasks related to various alarm panels.

The material and instructions covered in this manual have been carefully checked for accuracy and are presumed to be reliable. However, Telular assumes no responsibility for inaccuracies and reserves the right to modify and revise this manual without notice.

It is our goal at Telular to always supply accurate and reliable documentation. If a discrepancy is found in this documentation, please mail or fax a photocopy of the corrected material to:

Telular Security Products
Technical Services Department
2727 Paces Ferry Road SE
Suite 1-800
Atlanta, GA USA 30339
Fax: 678-945-1651

Repair and Warranty

If trouble is experienced with the *Telguard® Cellular Alarm Transmission System* please contact Telular Tech Support in the U.S.A. for repair and (or) warranty information. The customer (user) should not attempt any repair to the *Telguard® Cellular Alarm Transmission System*. Repair of this equipment should be referred to only qualified technical personnel.

Telular will repair or replace (our option) inoperative units for up to two years from date of manufacture. This excludes damage due to lightning or installer error. Unauthorized modifications void this warranty. Not responsible for incidental or consequential damages. Liability is limited to price of unit. This is the exclusive warranty and no other warranties will be honored, whether expressed or implied.

An RMA must be assigned by calling Telular Tech Support 800-229-2326 before returning product to:

Telular Corporation
Attention: Repair Depot
294 W Palatine Rd
Wheeling, IL 60090

RMA number must be on outside of box or product will not be accepted.

Future Testing and Limitations on Use

Telguard® is part of an advanced design alarm-communication system. It does not offer guaranteed protection against burglary and fire. Any alarm communication system is subject to compromise or failure.

The Telguard® will not work without power. Electrically powered devices will not work if the power supply is off for any reason, however briefly.

The cellular radio network, needed to transmit alarm signals from protected premises to a central monitoring station, may be inoperative or temporarily out of service. Cellular radio networks are also subject to compromise by sophisticated methods of attack.

This equipment, like any other electrical device, is subject to component failure. Although this equipment is designed to be long lasting, the electrical components could fail at any time.

Due to these limitations, we recommend that if the automatic self-test feature is not enabled, other arrangements be made with the user to test the system at least once every three months. Moreover, arrangements should also be made for on-site inspection/test by a licensed alarm installer at least once each year.

Terms and Conditions for Use of Telular Product

These Terms and Conditions are a legal contract between you and Telular Corporation for the title to and use of the Product. BY RETAINING AND USING THE PRODUCT YOU AGREE TO THE TERMS AND CONDITIONS INCLUDING WARRANTY DISCLAIMERS, LIMITATIONS OF LIABILITY AND INDEMNIFICATION PROVISIONS BELOW. IF YOU DO NOT AGREE TO THE TERMS AND CONDITIONS, DO NOT USE THE PRODUCT AND IMMEDIATELY RETURN THE UNUSED PRODUCT FOR A COMPLETE REFUND. You agree to accept sole responsibility for any misuse of the Product by you; and, in addition, any negligent or illegal act or omission of your or your agents, contractors, servants, employees, or other users of the Product so long as the Product was obtained from you, in the use and operation of the Product.

INDEMNIFICATION OF TELULAR CORPORATION (“TELULAR”)

YOU SHALL INDEMNIFY, DEFEND AND HOLD HARMLESS TELULAR FOR ANY OF THE COST, INCLUDING REASONABLE ATTORNEYS’ FEES, AND FROM CLAIMS ARISING OUT OF YOU, YOUR CLIENTS’ OR OTHER THIRD PARTIES’ USE OR OPERATION OF THE PRODUCT: (i) FOR MISUSE OR IN A MANNER NOT CONTEMPLATED BY YOU AND TELULAR OR INCONSISTENT WITH THE PROVISIONS OF THIS MANUAL; (ii) IN AN ILLEGAL MANNER OR AGAINST PUBLIC POLICY; (iii) IN A MANNER SPECIFICALLY UNAUTHORIZED IN THIS MANUAL; (iv) IN A MANNER HARMFUL OR DANGEROUS TO THIRD PARTIES; (v) FROM CLAIMS BY ANYONE RESPECTING PROBLEMS, ERRORS OR MISTAKES OF THE PRODUCT; OR (vi) COMBINATION OF THE PRODUCT WITH MATERIAL, MODIFICATION OF THE PRODUCT OR USE OF THE PRODUCT IN AN ENVIRONMENT NOT PROVIDED, OR PERMITTED, BY TELULAR IN WRITING. THE PARTIES SHALL GIVE EACH OTHER PROMPT NOTICE OF ANY SUCH COST OR CLAIMS AND COOPERATE, EACH WITH THE OTHER, TO EFFECTUATE THIS INDEMNIFICATION, DEFENSE AND HOLD HARMLESS.

WARRANTY and LIMITATIONS

TELULAR WILL REPAIR OR REPLACE (OUR OPTION) INOPERATIVE UNITS FOR UP TO TWO YEARS FROM DATE OF MANUFACTURE. EXCLUDES DAMAGE DUE TO LIGHTNING OR INSTALLER ERROR AS WELL AS UNITS THAT INCORPORATE MATERIAL, OR USED IN A MANNER OR ENVIRONMENT, NOT SPECIFICALLY AUTHORIZED IN THIS MANUAL. UNAUTHORIZED MODIFICATIONS VOID THIS WARRANTY. NOT RESPONSIBLE FOR INCIDENTAL OR CONSEQUENTIAL DAMAGES. LIABILITY LIMITED TO PRICE OF UNIT. THIS IS THE EXCLUSIVE WARRANTY, IN LIEU OF ALL OTHER WARRANTIES INCLUDING IMPLIED WARRANTIES OF MERCHANTABILITY, TITLE, DELIVERY, INFRINGEMENT OR FITNESS FOR A PARTICULAR PURPOSE AND NO OTHER WARRANTIES WILL BE HONORED, WHETHER EXPRESSED OR IMPLIED.

Table of Contents

Important Note	i
Foreword	i
Table of Contents	vii
General Description and Operation	1
Visual Tour	2
<i>TG-1 Express – First Look</i>	2
Features	3
<i>Operating Mode</i>	3
<i>Panel-Supplied Power</i>	4
<i>Single Line Interface Cable (SLIC)</i>	4
<i>Multiple Alarm Format Support</i>	4
<i>Complete Supervision of Communication Path</i>	5
<i>Telguard Automatic Self-test Report</i>	6
<i>Telguard Remote Query Capability</i>	7
<i>Programmable Supervisory Trip Output (STC) Relay</i>	7
<i>Diagnostic and Status LEDs</i>	8
<i>UL Listings</i>	8
Getting Ready	9
<i>Dealer Account Establishment</i>	9

<i>Subscriber Account Registration</i>	9
<i>Pre-Installation Checklist</i>	10
Installation	11
<i>Summary</i>	11
<i>Step 1: Register the Telguard Unit for Service</i>	11
<i>Step 2: Locate Unit and Measure Signal Strength (RSSI)</i>	12
<i>Step 3: Program, Activate & Transmit Alarms</i>	16
<i>Step 4: Connect the Supervisory Trip Output</i>	20
<i>Step 5: Connect and test the trip input (optional)</i>	23
<i>Step 6: Complete the Telguard Installation</i>	24
Appendix 1 – Connection Guide	26
Appendix 2 – Troubleshooting Guide	28
Appendix 3 – Detailed Specifications	32
<i>Dialer to Interface Electronics</i>	32
<i>Power</i>	32
<i>Digital Cellular Radio</i>	32
Appendix 4 – Parts List	34

General Description and Operation

The Telguard® TG-1 Express is a digital cellular radio alarm transmission device used to provide a primary transmission path (cellular) for Household alarm panels. When transmitting an alarm signal, the Telguard unit obtains its data from the alarm panel by way of a telephone interface. The Telguard will obtain all alarm signal information including monitoring station phone number, account number and all zones for every alarm transmission. The Telguard transmits a Link Request to the Telular Communication Center and, when a link acknowledgement is received, the Telguard handshakes with the alarm panel and causes it to transmit the alarm data. Telguard encodes the alarm data and transmits it to the Telular Communication Center over the cellular network. The Telular Communication Center performs a function similar to a central station receiver and issues the transmission acknowledgement when the last message in the transmission is received. After decoding and reformatting, the alarm signal is routed over the telco line (Public Switched Telephone Network - PSTN) to the appropriate alarm company central station for action.

In a typical alarm installation, Telguard Digital TG-1 Express is installed in the same area as the host alarm system and is connected directly to the host alarm panel via the Telguard's RJ-45 jack in the normal fashion. One programmable supervisory trip (STC) output is available for connection to the host control/communicator's trip zone input terminals in order to provide a Telguard trouble signal to the alarm panel. Additionally, automatic self-test and status-on-demand report signals are transmitted exclusively over the cellular network to the Telular Communication Center. The TG-1 Express receives operating power from the host alarm panel, and all cellular monitoring and supervisory functions are built in. No extra modules are required.

The UL Listed equipment at the Telular Communication Center (TCC) plays a key role in the operation of every Telguard. All Telguard units are required to use the Communication Center because of the alarm panel alarm signal format encoding and decoding requirements used in packet-data transmissions over the digital cellular network. The

Communication Center also manages the real-time databases for cellular service and a complete history of every Telguard unit's operating conditions. These conditions include programming setup information, alarm transmission information, supervisory trouble information, status information, and automatic self-test information.

Visual Tour

TG-1 Express – First Look

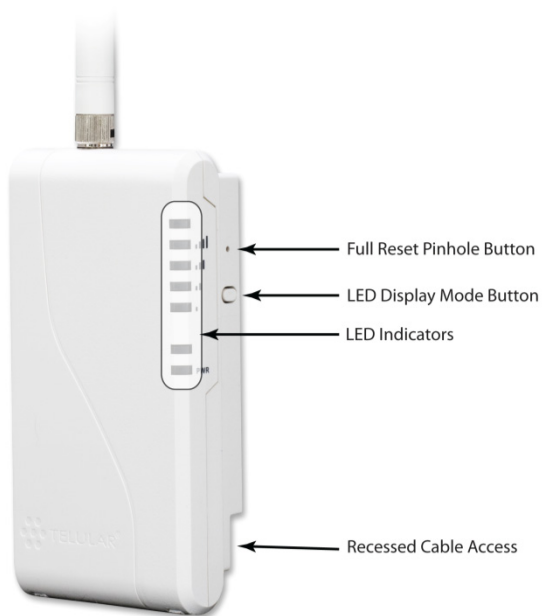

Inside the TG-1 Express

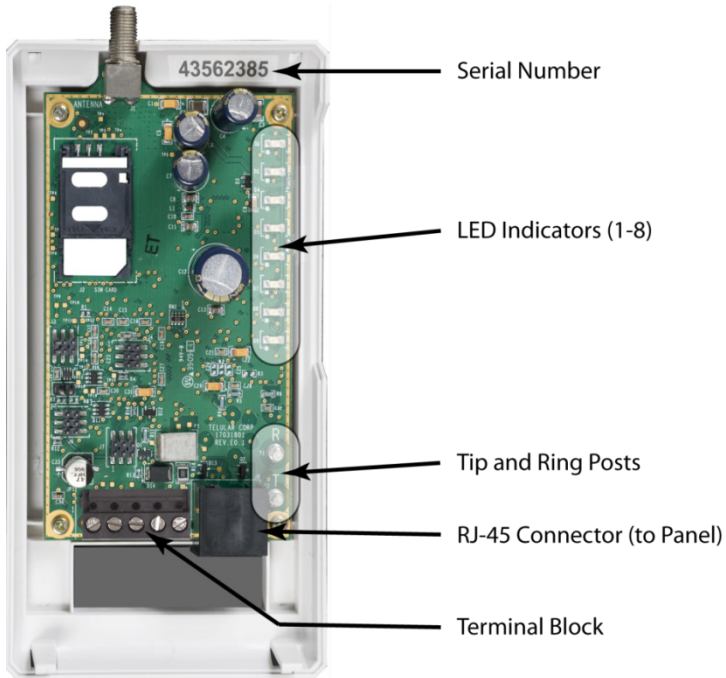

Features

This section summarizes the key features of the Telguard TG-1 Express.

Operating Mode

The Telguard Digital TG-1 Express is a digital cellular transmission device that is installed at the protected premises to provide primary alarm transmission integrity for household burglary and fire systems.

Panel-Supplied Power

The Telguard TG-1 Express has an extremely low power profile, and as such can usually be powered from the panel to which it is connected. At 39mA (average), the power required by the TG-1 Express is less than that used by many keypads.

Using the panel to provide power for the TG-1 Express allows for a simpler installation, and eliminates the need for additional A/C outlets.

For panels with very limited power capabilities, a Telguard TG-1 or TG-4 communicator should be used, both of which utilize a battery backed-up A/C power, separate from the panel.

Single Line Interface Cable (SLIC)

To further simplify installation, the TG-1 Express can be connected to the panel power using pins 2 and 7 of the RJ-45 connector for Ground and Power respectively. This allows the installer to connect both the communication path as well as the power to the alarm panel using a single cable.

Multiple Alarm Format Support

The default program setting of the Telguard TG-1 Express is for Auto Detection of the panel alarm format. The Auto Format Detect feature allows the Telguard to adapt to receive any listed format on every alarm transmission. If the alarm format is changed for whatever reason, the Telguard will sense the new format and accept the alarm signal.

In order for the host alarm panel to be compatible with the Telguard, the panel must be programmed to transmit alarm messages to the central station using one of the following non-extended formats:

- Pulse Formats:
 - 3+1 pulse; 10pps, Double Round, 1400Hz ack
 - 3+1 pulse; 20pps, Double Round, 2300Hz ack

- 3+1 pulse; 40pps, Double Round, 2300Hz ack
- 4+2 pulse; 10pps, Double Round, 1400Hz ack
- 4+2 pulse; 20pps, Double Round, 2300Hz ack
- 4+2 pulse; 40pps, Double Round, 2300Hz ack
- Ademco Contact ID
- Radionics Modem IIe or IIIa
- SIA2 (SIA-DC-03 level 2 release at 300 baud)
- DMP

Hexadecimal account numbers can be used with 3+1 or 4+2 formats, as well as Contact ID and Radionics (4 or 10 digits for Contact ID, 4 digits for Radionics).

Complete Supervision of Communication Path

The Telguard TG-1 Express continuously supervises the primary (cellular) communication path. If the cellular communications path becomes inoperative, the TG-1 Express generates a relay trip output that can be connected to a zone input of the host alarm panel and/or used to activate remote annunciation devices.

No Service Condition (NSC)

The Telguard unit declares a no service condition (NSC) when the measured "receive" cellular radio signal strength at the protected premises drops to -114 dBm or less. NSC is programmable to trip the supervisory relay output (STC relay) after a variable period of time. When the STC relay trips, the System Trouble Condition LED (STC LED) will flash 4 times. Restoral of this condition occurs when a measurable signal strength greater than -114 dBm is maintained for the trip period.

Radio Failure Condition (RFC)

Radio communications failure condition (RFC) is declared when Telguard is unable to transmit over the cellular network even with acceptable signal strength. RFC is indicated by the STC LED flashing 5 times. RFC is cleared automatically after 10 minutes.

Panel Presence Failure Condition (PPFC)

Panel presence failure condition (PPFC) is declared when the Telguard is unable to detect the presence of the host alarm panel. PPFC is indicated by the STC LED flashing 7 times. PPFC is restored immediately after the connection to the panel is restored.

Dial Tone Failure (DTF)

The Telguard continuously monitors the 30V supply circuit that provides dial tone to the alarm panel. A Dial Tone Failure (DTF) is declared when the 30V supply drops to 20V or less while the alarm panel is on-hook. The STC LED will flash 6 times and the STC relay will trip. Additionally, a TYPE 2 supervisory message is automatically transmitted to the Telular Communications Center. This condition will require contacting the Telular Communications Center for resolution.

Catastrophic Failure (CF)

Catastrophic Failure (CF) is any condition that causes the Telguard to stop functioning at all levels, most commonly because of power failure. The STC trip output is activated and visible indication is loss of all LED activity. If power is connected properly to the unit, please contact Telguard Technical Support for resolution.

Telguard Automatic Self-test Report

The Telguard automatic self-test signal is programmed to daily, weekly or monthly schedule as prescribed by contract. The central station receives the automatic self-test report in the same format that the alarm panel normally uses for communication over the telco line. The central station provides the Telguard self-test code along with the time and frequency of transmission when the Telguard is initially activated. The Communication Center captures all current and historical data pertaining to the operation of the Telguard when it processes the automatic self-test signal on to the central station. This data contains current operational status (C.O.S.) of the Telguard such as "All OK",

current trip input status, or any combination of the system trouble conditions, as well as the current signal strength. In addition, the data also contains historical data for supervisory events that occurred since the last self-test signal was transmitted. This data includes the number of occurrences of communications failure conditions and no cellular service conditions. This additional information is available by contacting Telular Technical Support or by visiting **www.TelguardOnline.com**.

Telguard Remote Query Capability

Although Telguard has the capability for a daily, weekly, or monthly automatic self-test, a separate feature is provided for determining the current operational status of every Telguard. This feature is called Remote Query and is used to provide real-time operational status for Telguard on-demand. It is useful in resolving STC events that are reported by the alarm panel to the central station. Authorized personnel can initiate the Remote Query at any time by calling Customer Service or by visiting www.TelguardOnline.com. The Remote Query causes Telguard to upload current operational status data and historical data, just as the automatic self-test described above, except that the query signal is controlled by the one who initiates it. The query signal is held in the Telguard database at the Communication Center for review and is not forwarded on to the central station.

Programmable Supervisory Trip Output (STC) Relay

The Telguard Digital TG-1 Express has one supervisory relay trip output (STC) and is energized in a powered-up state when no system troubles exist. It enables a supervisory trouble code to be transmitted to the central station when connected to an alarm panel's 24-hour instant input zone. The STC relay is programmable, using a standard touch-tone telephone or butt-set, to meet virtually any installation requirement.

The following supervisory features or combination of features are programmable to trip the STC relay in order to meet a variety of installation requirements:

- Trips on no service condition (NSC).
- Trips on radio communication failure condition (RFC).

The following system trouble features are embedded in the Telguard for tripping the STC relay and cannot be changed:

- Tripped when unit is not activated at the Telular Communications Center (TCC)
- Trips on *catastrophic failure* (CF) if all power is lost.
- Trips on *transmit-disable command* from the Communication Center. This radio command disables only the Telguard transmitter and would be used, for example, to shut down the Telguard due to a runaway panel dialer.

Diagnostic and Status LEDs

Seven LEDs are provided as a useful aid during installation and give installers an immediate visual indication of system status. The LEDs serve as indicators for activation, system trouble conditions, and communication indicators. They also can be used to provide a signal strength indication, similar to the signal strength bars on a cellular phone. See the installation section for details.

UL Listings

Model TG-1 Express (p/n TG1GX001) meets the requirements for all Household Burglary, Household Fire, and Combined Household Burglary/Fire installations. It has a plastic enclosure and dipole antenna. TG-1 Express is UL Listed for the following:

- UL Household Burglary
- UL Household Fire
- UL Household Burg/Fire Combination

Getting Ready

The Telguard can only be activated when all the necessary accounting information has been entered into the customer database located at the Telular Communication Center. The database includes information about the customer account, unit location, and system test plan information.

Dealer Account Establishment

Prior to registration of any Telguard unit, a Dealer Account must be established. Once the Dealer Account has been established and service credit line established between the Security Dealer and Telular, a service registration form may be submitted. Establish your Dealer Account by completing the Telular Cellular Service Dealer Account Application that is included with every Telguard and faxing it to Telular Customer Service at 678-945-1651. Once the application has been completed you will receive an acknowledgment within 1 business day or sooner. This is a one-time event; the acknowledgment from the Telular Technical Service will include a Dealer Account Number that will be used for all Telguard registrations.

Subscriber Account Registration

A completed Registration Form is required by Telular to register the Telguard unit prior to leaving for the job site. Service registration of the Telguard can be accomplished:

- Online – Complete the Registration Form online at www.telguardonline.com
- By Email – Email the completed Registration form to cellservice@telular.com.
- By FAX – Fax the completed Service Registration Form that is shipped with each Telguard unit to Telular Customer Service at 678-945-1651.

Service registration occurs within 30 minutes of receipt of the registration form. The subscriber record is created and the Telguard device will be ready for activation. Activation occurs automatically upon transmission of the first alarm signal. Telular Technical Service is open from 8:00 AM – 8:00 PM EST Monday – Friday, 9:00 AM – 5:00 PM EST Saturday and closed during major holidays; registration forms received after hours will be processed by 9:00 AM EST the next business day.

Pre-Installation Checklist

Before attempting to connect Telguard to the host alarm panel, please note the following:

Be sure you have all the proper parts before you go to the job site. The following items are shipped with each Telguard unit:

- Registration Form – The registration form **must be completed and sent before leaving for the job site** to install the Telguard unit.
- Basic TG-1 Express unit, with antenna.
- TG-1 Express Installation Guide.

You must also have certain installation test tools:

- A standard telephone or lineman's butt-set is required at the job site for use in programming the unit.
- Screws and a screwdriver will be required to attach the unit and antenna to the wall.
- In order to connect the STC relay output to the alarm panel, stranded electrical wire will be required. The terminal strips can accommodate solid or stranded wire sizes from 14 to 22 gauge.
- A standard RJ31X-to-spaded leads cable will be required to connect the TG-1 Express to the panel. These are usually supplied with the alarm panel.

Note: Your unit may be subject to airtime charges for unintended use. Telular Cellular Service offers several cellular service rate plans. Check the registration form that was shipped with your unit or call us to determine what rate plan each unit is operating under.

Installation

Summary

There are six steps in installing Telguard properly. IF YOU DO NOT PROCEED IN THE ORDER AND MANNER PRESCRIBED, YOU MAY NOT COMPLETE THE INSTALLATION IN THE TIME ALLOCATED. These six steps are summarized below and then explained in detail in the remainder of this manual.

1. Register for Telguard service
2. Locate Unit and measure signal strength
3. Program, activate and transmit alarm panel alarms
4. Connect supervisory trip outputs
5. Connect trip input (optional)
6. Complete installation

This six-step installation approach provides the alarm installer with the easiest and fastest method of properly installing Telguard. Please follow the instructions carefully and if you should need assistance or have any questions, call Telular TECHNICAL SERVICE at 1-800-229-2326 extension 9.

Important: Dealer Account Establishment and service registration form must be complete prior to Installation (see previous section).

Step 1: Register the Telguard Unit for Service

Installation Tip: Register for service prior to leaving for the job site to avoid a second trip.

The registration form must be completed before leaving for the job site to install the Telguard product. The registration form may be completed by:

- Fax – 678-945-1651
- Email – cellservice@telular.com
- Online – www.telguardonline.com

Registration requests sent by fax or email are processed Monday-Friday from 8:00AM to 8:00PM and Saturday 9:00AM to 5:00PM EST within 30 minutes of receipt of the registration form. Registration requests made online through www.telguardonline.com are processed immediately, 24/7.

Activation occurs automatically upon transmission of the first alarm signal.

Step 2: Locate Unit and Measure Signal Strength (RSSI)

Locate Unit

Pick a spot next to the alarm panel where you think the Telguard will be mounted and place the unit down temporarily in that spot. Do not mount it permanently now, since it may need to be moved to receive a better cellular radio signal or a remote high-gain antenna may be necessary.

Note that for a UL compliant installation, the Telguard TG-1 Express must be mounted in the same room as, and not more than 20ft from the alarm panel.

Connect DC Power

Before connecting the power cables to the alarm panel, make sure that the panel's power source and battery are disconnected.

To connect power to the TG-1 Express using terminal block:

1. Connect the black and red leads to the GND and PWR terminals of the alarm panel. The specific terminals used on the panel will depend on the panel make and model.
2. Connect the black and red leads to the GND and PWR terminals on the TG-1 Express.
3. Reconnect the alarm panel's power supply, and ensure that the PWR light (LED 8) on the TG-1 Express is illuminated.

To connect power to the TG-1 Express using the POTS connection:

1. Using a standard RJ-31X to spaded lead cable, connect the orange and blue leads to the GND and PWR terminals of the alarm panel.
2. Connect the remaining leads to the Telco terminals in the alarm panel, per the panel's instruction.
3. Connect the other end of the cable to the RJ-45 jack on the TG-1 Express.

Reconnect the alarm panel's power supply, and ensure that the PWR indicator (LED 8) on the TG-1 Express is illuminated.

<u>Recommended Wire Size</u>	<u>Length Not to Exceed</u>
18 ga	20 ft
16 ga	40 ft
14 ga	60 ft

Connect Antenna and Temporarily Place Unit

The Telguard is supplied with an antenna. In most cases the antenna may be mounted directly to the Telguard. If a stronger radio signal is required, the antenna must be moved to a better signal location using a Telular antenna cable and bracket accessory (sold separately). The performance of the Telguard antenna may be affected by the wall material and materials contained within the wall chosen for mounting. These effects may not be clearly identified by RSSI monitoring alone. The wall materials may have a more pronounced effect on the antenna's transmit band performance.

When selecting a mounting location, do not mount this unit in an area where the general public could reasonably be within 20cm (8 inches) of the antenna.

Note 1: Optimum RF performance can usually be found at the highest point within a building with the fewest number of walls between the Telguard's antenna and the outside of the premises.

Note 2: To avoid interference with other electronic devices operating in the area, avoid mounting the Telguard's antenna near other electronic devices.

Note 3: The Telguard TG-1 Express unit with supplied dipole antenna is designed for indoor installations ONLY.

These considerations should be coupled with the best RSSI indication obtainable. Care should be taken to ensure that a large metal object such as a refrigerator or a metal cabinet is not located on the opposite side of the wall.

If moving the Telguard to a different location is not practical, then you may need a cable and remote the antenna in order to receive adequate radio signal strength. Pick a high, visually secure spot using the guidelines below.

Tips for Improved Radio Signal Reception

- The higher the antenna the better. So, start in the drop ceiling above the unit and proceed up from there, to the roof if necessary.
- Remember, the antenna should be as inconspicuous as possible for greatest visual security.
- Try to keep the antenna away from sources of RF interference, including pumps, compressors, ovens, etc., or where metal objects can shield it or otherwise block the cellular radio RF signal.

- Place the antenna perpendicular to the ground, either right side up or upside down. Do not mount the antenna horizontally.
- Always use an antenna mounting bracket. Do not mount the antenna such that it is in contact with another object, as this may interfere with cellular reception and transmission.

Measure Received Signal Strength (RSSI) for Best Antenna Placement

Measure the received signal strength by pressing the RSSI button. This switches the LEDs to signal strength mode. Now, slowly move the unit or remote antenna to achieve maximum signal strength. Pick the place where the most LEDs (up to four) are lighted.

RSSI Value	Illuminated LEDs	RF dBm
NO SVC	LED 5 = slow flash, LED 4-2 = off	n/a
1	LED 5 = on, LED 4-2 = off	≤ -111 dBm
1½	LED 5 = on, LED 4 = slow flash LED 3-2 = off	≥ -110 dBm
2	LED 5-4 = on, LED 3-2 = off	≥ -100 dBm
2½	LED 5-4 = on, LED 3 = slow flash LED 2 = off	≥ -90 dBm (Minimum signal strength required)
3	LED 5-3 = on, LED 2 = off	≥ -80 dBm
3½	LED 5-3 = on, LED 2 = slow flash	≥ -70 dBm
4	LED 5-2 = on	≥ -60 dBm

LED Function Table – View RSSI Mode (RSSI button)

Note: LED #1 = on, indicates more than one cellular tower.

If you cannot obtain a signal strength reading of 2½ (TWO LEDS ON SOLID AND THE THIRD LED ON SLOW FLASH), you will probably need

to move the unit and/or remote antenna higher, or switch to a special antenna as described below.

Antenna Options

Antenna problems are unlikely unless the premises are located in a fringe network coverage area, in a building below ground level, or in a metal structure. If you require a higher gain antenna or a longer cable assembly please contact your Telular Sales Representative at **800-229-2326**. Telular offers a variety of high quality low loss antenna cables as well as high gain antennas.

Step 3: Program, Activate & Transmit Alarms

Confirm that the Telguard enables the host alarm panel to transmit alarm signals over the cellular radio network. The Telguard unit will confirm registration with the Telular Communication Center if the registration form was submitted prior to installation. During the processing of the first alarm signal over the cellular network the Telguard will transmit all of the parameters from the Telguard along with the information (central station number and account code) from the alarm panel. Once this information is received, the TCC will transmit a message back to the Telguard indicating that the unit is registered. When this message is received the LED'S on the unit will begin operating in normal mode; LED #1 will be on solid.

The first alarm is to confirm registration and activate the Telguard unit. The first alarm will NOT be transmitted to the central station.

Special LED Indications During Activation

If the Telguard fails the activation process, it will be displayed on the LEDs.

- If LED #1 and LED #4 are flashing, the Telguard serial number is not in the database at the Telular communication center. Call Telguard Technical Support to verify correct serial number.

- If all of the LEDs are flashing, the activation message was NOT received at the Telular communication center. Retry transmitting the activation message. If the TG-1 Express fails a second time to register, check the signal strength. If the signal strength is OK, then call Technical Support.
- If no LEDs besides the power LED are lit or flashing, it may indicate insufficient power supplied from the alarm panel. Press the LED mode button to change the LEDs to RSSI mode. If still no LEDs are lit, check the voltage being supplied to the Telguard, and ensure that it is above 8V.

Important: On either a registration failed activation or activation error, the unit must be cleared by pushing the RSSI button twice. THE ACTIVATION MESSAGE MUST BE RESENT OR THE TELGUARD UNIT WILL NOT TRANSMIT ANY SIGNALS.

System Status LEDs	Activation Indications
ALL LEDS FLASHING	Failed Activation – Signal Too Weak
LED #1 & LED #4 FLASHING	Activation Error – Call Telguard Technical Support
LED #1 ON	Activation Successful

System Status LEDs Table

Status LED #2	Indication
1 FLASH	STC – Low Input Power
2 FLASH	N/A
3 FLASH	N/A
4 FLASH	NSC – No Service
5 FLASH	RFC – Radio Failure
6 FLASH	DTF – Dial Tone Failure
7 FLASH	PPF – Panel Presence Failure

System Trouble Condition, STC (LED #2) Table

Connect Alarm Panel to TG-1 Express

If the alarm panel and the TG-1 Express were not already connected in Step 2, plug the modular jack of the alarm panel to the RJ-45 jack on the Telguard.

Set Up & Program the Operating Parameters in the Telguard

When the Telguard is received from the factory and is powered up for the first time, it is immediately ready for activation, provided the default settings are what you want. The STC LED #2 will flash to indicate any failure conditions. If changes are required to the default settings, the Telguard can be programmed using a line-man's butt-set connected to T & R Test Points or a POTS phone connected to the RJ-45 jack (where the alarm panel is normally connected).

Key Sequence	Description
# ##*	Enters the programming mode
*	Saves and stores changes

Command Key Sequences for POTS Programming Table

To Program the Telguard:

1. Make sure the Telguard unit has finished initialization and is idle.
2. Connect a POTS phone or lineman's butt set on the alarm panel jack.
3. Take the POTS phone off hook or put the butt set in talk mode. You should hear dial tone.
4. Dial ##*, and you should hear one beep.
5. Dial #*, and you should hear one beep.
6. Dial the POTS command number 8XX; you should hear beep.
7. Enter the command data; you should hear 2 beeps.

8. After the last POTS command, dial * and you should hear 2 beeps , then hang up to terminate the POTS session;.

The syntax for programming a specific memory location is as follows:

MEMORY LOCATION (3-digits) (Telguard will respond with 1 beep), then **VALUE** (Telguard will respond with 2 beeps).

Then press *, you will hear 2 beeps then hang up. This saves the change and exits the programming mode.

Mem Loc.	Field	Setting (default indicated in bold)
851	STC Relay Output Reporting Normally Closed	Enter the SUM TOTAL of the events that you wish to trip the STC relay by ADDING the corresponding values: 00 = STC Relay Output Not Used 08 = NSC 16 = RFC 32 = DTF 57 = ALL
852	STC Trip Delay for NSC	1=30 seconds 2=60 seconds 3=3 minutes 4=10 minutes 5=20 minutes 6=30 minutes 7=45 minutes 8=60 minutes 9=24 hours
858	STC History	0 = terminate STC history display mode 1 = start STC history display mode 2 = clear STC history
868	PPF Delay Timer	0 = disabled , 1 = 10 seconds, 2 = 20 seconds, ... 15 = 150 seconds

873	Trip Input Reporting	0 = no report 1 = report trip
874	Trip Input Restoral Reporting	0 = no report 1 = report restoral
875	Trip Input Swinger Function	0 = swinger function disabled 1 = swinger function enabled
899	Factory Default Unit	

Verify Alarm Signal Transmissions over Cellular

Trip several alarms on the alarm panel and verify that the central station received them by calling the central station operator. Use a lineman's butt-set in **MONITOR MODE** and connected to Telguard's "T" and "R" test pins to "listen" to communications between the alarm panel and Telguard. After the panel has finished communicating with the Telguard unit, ACK LED #4 will come on solid while waiting for an acknowledgement from the Telular message center.

If you are having problems getting reliable alarm signal transmissions, additional adjustments may be necessary.

- Recheck signal strength. You need **RSSI = 2½ (TWO LEDS ON SOLID AND THE THIRD LED FLASHING)** for adequate signal strength. Also, check antenna connector and make sure it is seated correctly.
- **Call Telular Technical Service, 1-800-229-2326 option 9**, and request the Telular Communication Center operator to check the Telguard programming configuration for proper operation and **proper communications format**.

Step 4: Connect the Supervisory Trip Output

Connect and test the supervisory trip outputs to the alarm panel.

Activation of a local alarm or strobe light may be desirable when a trip is declared. The STC trip output can be used directly to activate a local signaling device, provided that the trip output is not needed to trip the host control/communicator at the same time. If both a local signal and a control trip input are required, then external relays are needed to provide additional uncommitted contacts.

Decide on a STC Trip Output Strategy

The Telguard provides the host alarm panel with one supervisory trip output for reporting a Telguard system trouble code to the central station. The supervisory trip outputs are programmable via a touch-tone telephone or butt-set to suit various installation requirements. The programming options for these supervisory trip outputs can be any combination of the following:

- **Always Off:** Disables all relay supervisory functions.
- **NSC:** Trips after a variable length of time (default is 60 seconds) on no service condition due to loss of RF signal strength. Restoral of this condition occurs when a measurable signal strength greater than -114 dBm is maintained for the trip period.
- **RFC:** Trips on radio failure to communicate with the Telular Communication Center
- **DTF:** Trips on an internal failure in the dial tone circuitry within the TG-1 Express

Use the butt-set programming instructions outlined in the previous step to program the STC trip output strategy.

Reprogram Alarm Panel to Send Proper Code

Reprogram alarm panel, if necessary, to send proper alarm code when tripped by the Telguard's supervisory output. Program zone restoral as desired.

Check Proper Operation of Telguard Supervisory Output

Check for proper operation of each programmed supervisory output by causing it to trip the alarm panel and be sure the proper LED illuminates and that the proper trouble code is reported to the central station. Skip the testing of any supervisory functions that have not been enabled. Note that the yellow MODE LED #3 starts to flash when the alarm panel goes off-hook to report the alarm signal over cellular, however, an alarm/event will only be transmitted if the STC is being monitored by an available zone in the panel.

- **No Service Condition (NSC):** Disconnect the antenna from the Telguard. Check to see that the STC LED #2 flashes 4 times in the programmed period of time (default is 60 seconds) and the alarm panel transmits the STC trouble code over the telco line indicating loss of RF signal strength. Reconnect the antenna and check to see that the STC LED #2 goes off within after a period of time, indicating RF signal strength restored.
- **Note:** The Received Signal Strength (RSSI) must be less than -114 dBm in order to cause a NSC condition. If the Telguard is located in a high signal strength area (close to a cellular tower), it is possible for the signal strength to be greater than -114 dBm even with the antenna disconnected.

Verify the STC History

The POTS command 858 was designed to display STC history for troubleshooting purposes. This feature increases in-field efficiency by eliminating the need for installers to call Telular for STC report data.

To access the STC history, enter the POTS programming mode as described in the previous section. Enter the POTS command 858, and wait for the confirmation tone (2 beeps). Enter "1" to start the history display. The STC LED will light for 3 seconds, then each STC in the history log will be displayed as a series of flashes of the STC LED. At the end of the history, the STC LED will again light for 3 seconds, denoting

the end of the history log. After the STC history is displayed, the STC LED will return to normal operation. To cancel the history playback at any time, use the POTS command 858 with a parameter value of "0".

The STC history log can be cleared by using the POTS command 858 with a parameter value of "2". The STC history log is also cleared when the Telguard unit is reset.

Step 5: Connect and test the trip input (optional)

In addition to the interface to the alarm panel, a single trip input may be connected to the terminal block of the TG-1 Express. When the input is tripped, a supervisory message is sent to the central station via the Telguard Message Center. This allows an external relay, separate from the alarm panel, to be connected to the Telguard unit in order to provide independent sensor input for other functions, such as tamper detection.

The trip input is connected to the external relay by wiring one side of the external relay to the TRIP IN terminal, and the other side to either the GND terminal or to the chassis ground on the TG-1 Express circuit board.

Note that trip inputs are normally wired such that there is a 2.2k Ω resistor in parallel with the external relay, so that a tamper condition (i.e. a cut wire) can be detected.

The functionality of the trip input can be customized at installation time using an ordinary phone set or a lineman's butt-set, in a similar manner to other Telguard programming options. The relevant POTS programming commands are:

Mem Loc.	Field	Default	Setting
873	Trip Input Reporting	0	0 = no report 1 = report trip

Mem Loc.	Field	Default	Setting
874	Trip Input Restoral Reporting	0	0 = no report 1 = report restoral
875	Trip Input Swinger Function	0	0 = swinger function disabled 1 = swinger function enabled

When the trip input functionality is being used, opening the trip contact will cause the Telguard device to send a message to the Telguard Message Center, which in turn will cause the TMC to send a message to the central station. If the Telguard unit is configured to report restorals, the contact closure will also be reported.

The message that is sent from the TMC to the central station is configurable in Telguard Online, or by a Telguard Customer Service Representative. The TG-1 Express unit will automatically be configured with a unit template that allows configuration of the trip input feature, including the message that is sent to the central station. There is a default event configured for each alarm format, so that if the Telguard unit is configured with the butt-set to send trip input events to the TMC, a default notification will be sent to the central station.

Swinger Function

The swinger function is designed to reduce the incidence of excessive messaging and alarms due to faulty equipment or installation. If enabled, the swinger function will discontinue sending trip input messages to the TMC once ten trip events are detected within a 10 minute period. The Telguard device will resume sending trip input messages to the TMC after a ten minute period without trip events.

Step 6: Complete the Telguard Installation

The last step is to permanently mount the Telguard.

1. Attach earth ground to the grounding screw located on lower left-hand corner of printed circuit board assembly and permanently mount the Telguard enclosure.
2. Install the mounting screws (not supplied). The “keyhole” mounting holes on the back of the TG-1 Express are 2.5” apart, center-to-center.
3. Slide the enclosure onto these screws.

Appendix 1 – Connection Guide

Wiring Diagram

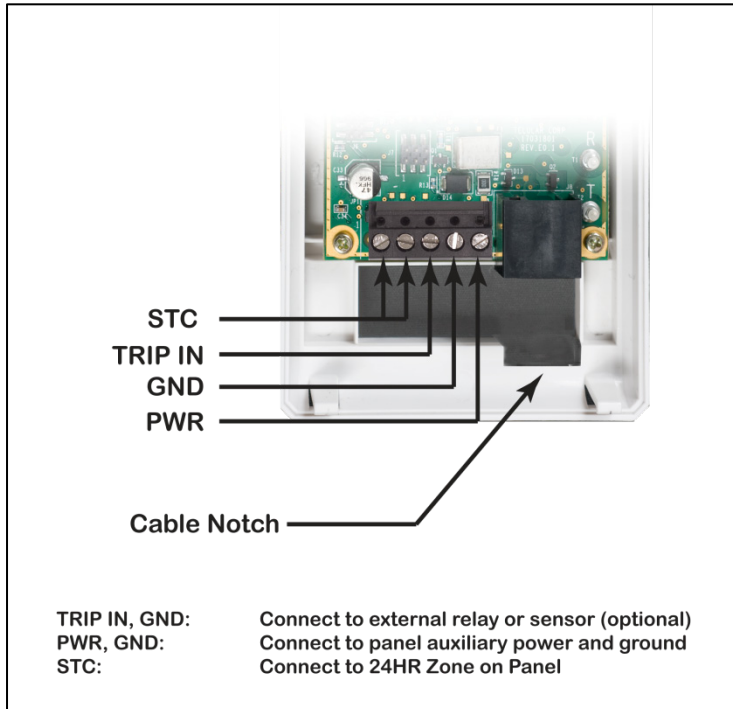

Attaching the RJ-45 Cable

The RJ-45 cable to the panel can be attached to the TG-1 Express either with the enclosure open or closed. A notch in the rear opening of the enclosure is provided to allow better cable access. Note that, as with other Telguard products, the RJ-45 cable to the panel, as well as all other wiring, should be routed through the rear cable opening, to allow the plastic lid of the TG-1 Express to be closed properly.

RJ-45 Pin Assignments

Pin	Wire Color	Assignment
1	Gray	R1
2	Orange	TG-1 GND (when using SLIC)
4	Red	R (Ring)
5	Green	T (Tip)
7	Blue	TG-1 Power (when using SLIC)
8	Brown	T1

Main Terminal Strip Pin Assignments

Terminal Strip Pin	Definition	Connects To	Function
1 STC 2 STC	Supervisory Relay Trip output for programmable trouble conditions. Normally Closed	24-hour trip zone input on host alarm panel.	Enables transmission of programmed supervisory trouble code (see diagram or installation section)
3 TRIP IN	Trip input	External trip input	Allows an external relay to trigger an alarm signal
4 GND 5 PWR	DC power input	Auxiliary power and ground of alarm panel	Provides primary power to TG-1 Express

Compatible Alarm Panels

The TG-1 Express is compatible with all popular alarm panels, and many specialized panels as well. For a complete listing of panels for which the TG-1 Express is UL cross-listed, please consult the TG-1 Express technical specifications at www.telguard.com.

Appendix 2 – Troubleshooting Guide

This section provides a summary of all LED indications and their meanings, as well as the expected behavior of the TG-1 Express under various exception conditions.

LED Indicator Guide – Normal Operating Mode

LED Symbol	Color	Showing	Indication
LED #1 Activation	Green	Solid On	Unit is activated at the message center and enabled
		Off	Unit not activated at the message center (and disabled)
		Flashing	Unit is activated but disabled
LED #2 STC (System Trouble Condition)	Red	Off	<i>ALL OK</i>
		1 Flash	STC – Low Input Power
		2, 3 Flashes	N/A
		4 Flashes	STC – No Service
		5 Flashes	STC – Radio Failure
		6 Flashes	STC – Dial Tone Failure
		7 Flashes	STC – Panel Presence Failure
LED #3 MODE	Yellow	Flashing	Telguard TG-1 Express communicating with alarm panel
		Off	Idle state
LED #4 Acknowledgement	Red	Flashing	When flashing with LED #1 unit has failed activation.0 CALL TELGUARD TECHNICAL SUPPORT

		Off	TG-1 Express initialized
		On	TG-1 Express is waiting for response from Telular Communication Center
LED #5 Radio	Green	Short Flash (1 sec)	Radio receiving message
		Long Flash (2 sec)	Radio sending message
LED #7 Trip Input	Green	Solid On	Trip input activated
		Off	Trip input not active or restored
LED #8 Power	Red	Solid On	Power connected to unit

LED Indicator Guide –RSSI Mode

RSSI Value	LED's Lighted	RF dBm
NO SVC	LED 5 = slow flash, LED 4-2 = off	n/a
1	LED 5 = on, LED 4-2 = off	≤ -111 dBm
1½	LED 5 = on, LED 4 = slow flash LED 3-2 = off	≥ -110 dBm
2	LED 5-4 = on, LED 3-2 = off	≥ -100 dBm
2½	LED 5-4 = on, LED 3 = slow flash LED 2 = off	≥ -90 dBm (Minimum signal strength required)
3	LED 5-3 = on, LED 2 = off	≥ -80 dBm
3½	LED 5-3 = on, LED 2 = slow flash	≥ -70 dBm
4	LED 5-2 = on	≥ -60 dBm

Note: If LED #1 is on, more than one cellular tower is available.

Troubleshooting Quick Reference Table

Telguard Event		LED Indication	Relay Output	Radio Message	Action
STC Telguard System Trouble Conditions	LIP	STC LED flashes 1 time.	None	None	Check input voltage on the power supplied from the panel.
	NSC	STC LED flashes 4 times.	Optional	None	The Telguard will continue to validate signal strength, and remove NSC when signal returns.
	RFC	STC LED flashes 5 times.	Optional	None	Wait for RFC restoral.
	DTF	STC LED flashes 6 times.	Yes	Yes	Internal 30V supply circuit failure. Return unit for repair on RMA.
	PPF	STC LED flashes 7 times.	No	Yes	Wait for PPF restoral.
Not Activated		Activation LED #1 off	Yes	None	Telguard will not function until unit is activated.
Telguard Remote Query activated by Customer Service.		Radio LED #5 flashes during transmit	None	Yes (Status data)	Telguard will send Status data to Telguard customer service for review
Telguard Activation and Configuration Upload		Radio LED #5 flashes during transmit	None	Setup data	Telguard sends setup configuration to the TCC and switches to READY state.
Disable TX – Communication Center Activated.		Radio LED #5 flashes when transmitting	Yes	Yes (Status data)	TX capability is disabled until further notice.

Appendix 3 – Detailed Specifications

Dialer to Interface Electronics

- Line voltage: -30 VDC into standard telephone device when on-hook.
- Dial tone: Precision 350 + 440Hz +/- 1%. 10 digits dial out capability.
- Mode: Loop start only. 25mA +/- 10% off-hook.
- Protected by U.S. Patents: 4,658,096; 4,775,997; 4,922,517; 4,737,975; 4,868,519; 5,134,644.

Power

- Nominal DC current draw:
 - 39mA @ 12V (idle)
 - 200mA @ 12V (transmitting)

Digital Cellular Radio

The Telguard TG-1 Express radio supports GSM/GPRS cellular protocol. It is equipped with an integrated radio transceiver conforming to all the requirements of the GSM Phase 2+ tests specified in GSM 11.10. The TG-1 Express transceiver is FCC compliant, meeting all of the requirements of Part 24 and SAR testing. It is also compliant to the PTCRB NAPRD03 requirements.

- Frequency range: GSM 850/1900MHz,
 - 824MHz-849MHz
 - 1850MHz-1909MHz
- Antenna Port: SMA connector (female), 50-ohm
- Receiver Sensitivity: -102dBm
- Transmit Power:
 - EGSM 850MHz: Class 4 (2 watts)
 - GSM 1900MHz: Class 1 (1 watt)

- FCC ID: N7NWISMO228
- Supplied Antenna: Dipole
- Physical Size: 5.6"H x 2.9"W x 1.3"D.
- Shipping weight: 1.1 lbs.
- Operating Environment: 0° C to +49° C; 0 - 85% humidity (non-condensing).

Appendix 4 – Parts List

Basic Hardware:	
Model TG-1 Express p/n TG1GX001	Model TG-1 Express (p/n TG1GX001) meets the requirements for Household Burglary, Household Fire, and Combination Burglary/Fire installations. It has a plastic enclosure, and dipole antenna. TG-1 Express is UL Listed for the following: UL 1023 – Household Burglary UL 985 – Household Fire UL Household Burg/Fire Combination
General Accessories:	
CTX-12	12 feet SMA/TNC antenna cable and mounting bracket. The CTX-12 is required for all ACD and external antenna accessories.
ACD-12	12 feet of antenna cable and mounting bracket
ACD-35	35 feet of low loss high performance antenna cable and mounting bracket
ACD-50	50 feet of low loss high performance antenna cable and mounting bracket
ACD-100	100 feet of low loss high performance antenna cable and mounting bracket
HGD-0	High Gain Directional Antenna
EXD-0	Low profile, dual band antenna with integrated wire ground plane.
LPD-0	Low profile, dual band antenna with integrated disc ground plane.