

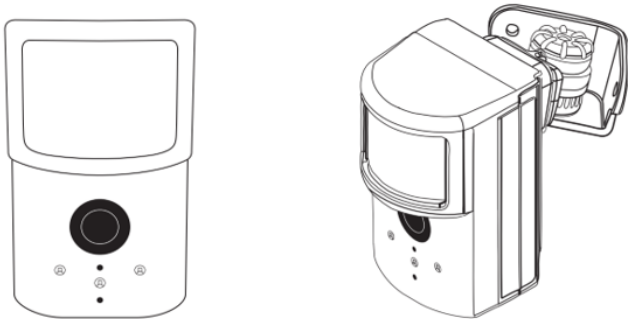

Interlogix Simon XTi Image Sensor Installation Guide - ADC-IS-300-LP



PRODUCT SUMMARY & TECHNICAL SPECIFICATIONS

The Image Sensor is a pet immune PIR (passive infrared) motion detector with a built-in camera designed to capture images during alarm or non-alarm events when motion is detected.

Product Features:

- Communicates wirelessly to the security control panel
- 35 foot detection range with a 90 degree horizontal FOV
- Configurable PIR sensitivity and pet immunity settings
- Image: VGA 640x480 pixels
- Color Images (except in night vision)
- Night vision image capture with infrared flash (black & white)
- Tamper detection, walk test mode, supervision
- All systems can support up to three Image Sensors
- UL 639 certified

Technical Specifications:

- Alarm.com Model Number: ADC-IS-300-LP
- Interlogix Part Numbers:
- Power Source: Recommended 2 AA 1.5v Energizer Ultimate Lithium Batteries.
- Batteries: Refer to the Batteries section for details



- Operating Temperature Range: 60° to 80°F
- Weight: 3.1 oz. (with batteries and without mounting accessories)
- Dimensions: 3.1” h x 1.8” w x 2.3” d
- Supervisory Interval: 100 minutes (sensor), 3 hours (alarm hardware)
- Wireless Signal Range: Greater than 400 ft open air
- Color: White
- Recommended Mounting Height and Angle: Refer to the Recommended Install Height and Angle Table
- Motion Profiles & Sensor Range: Refer to the PIR Sensitivity Settings Table

HARDWARE COMPATIBILITY REQUIREMENTS – By Panel

Panel	Panel Version	Module Firmware	Extra Hardware	Other
Simon XTi	V1.0+	Firmware 151+	Requires Image Sensor Daughterboard for modules with firmware 185 or lower. Compatible with all daughterboard versions. Note: The Image Sensor radio is built into modules with firmware versions 187+, so modules with this firmware do not require an Image Sensor daughterboard to be installed.	No

OTHER FEATURE COMPATIBILITY

Two-Way Voice Compatibility - Images cannot be transmitted while a Two-Way Voice call is in session. When the Image Sensor is installed on a system with Two-Way Voice over the cellular network, image transmission during an alarm may be interrupted by the two-way session. The image transmission resumes once the call has terminated.

PET IMMUNITY SETTINGS

Two parts to making the Image Sensor pet immune:



1. Set PIR sensitivity settings to “low”,
2. Mount set at a height of 6 ft, and install the sensor with the 6 degree mounting angle.

BATTERIES

Battery type: The Image Sensor uses 2 AA 1.5v Energizer Ultimate Lithium batteries (UL compliant).

Expected Battery Life: Approximately 4 years with lithium batteries.

Voltage Thresholds: With lithium batteries, low battery alerts are issued at 3.05V. The sensor cannot operate when the voltage reads below 2.30V.

Low Battery Notification: Panel will display a low battery alert for the sensor and/or notifications are issued via the Alarm.com platform if the customer has subscribed to this notification type.

Replacing batteries: To replace the sensor batteries, slide the front of the sensor up off the sensor-back. Dispose of used batteries per the battery manufacturer instructions and following local regulations.

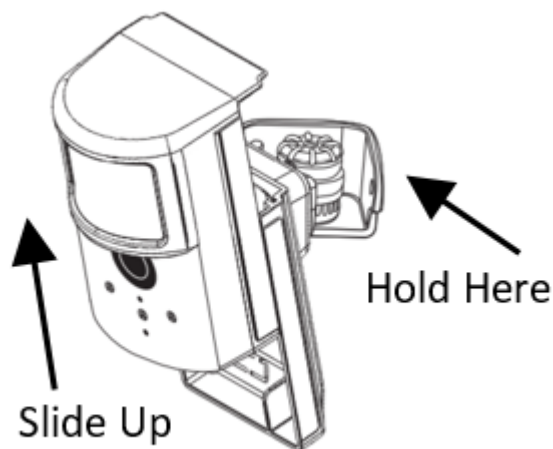









CAMERA LED REFERENCE CHART

Camera LED Chart: Refer to this chart to understand the camera LED patterns.



LED Reference Guide

Status

-  **Blinking Red**
Sensor Power Up | ~3 seconds
-  **Solid Red**
Memory Check | ~10 seconds
-  **Blinking Yellow**
Searching for Unknown Network | ~2 minutes
-  **Blinking Green**
Searching for Known Network | ~2 minutes
-  **Intermittent Rapid Blinking Red**
Network Connectivity Error | Continuous
See Troubleshooting section on page 9.
-  **Solid Yellow**
Sensor Found Network | ~5 seconds
-  **Blinking Yellow & Green**
Syncing | Up to 5 minutes
-  **Solid Green**
Connected and Synced | ~5 seconds

Troubleshooting

-  **Rapid Blinking Red**
Network Reset | Hold the Reset button for 10 seconds or until the LED blinks rapidly.



LED Status Chart

LED Pattern Key

● Solid ● Blinking ● Multi-color Blinking ● Rapid Blink

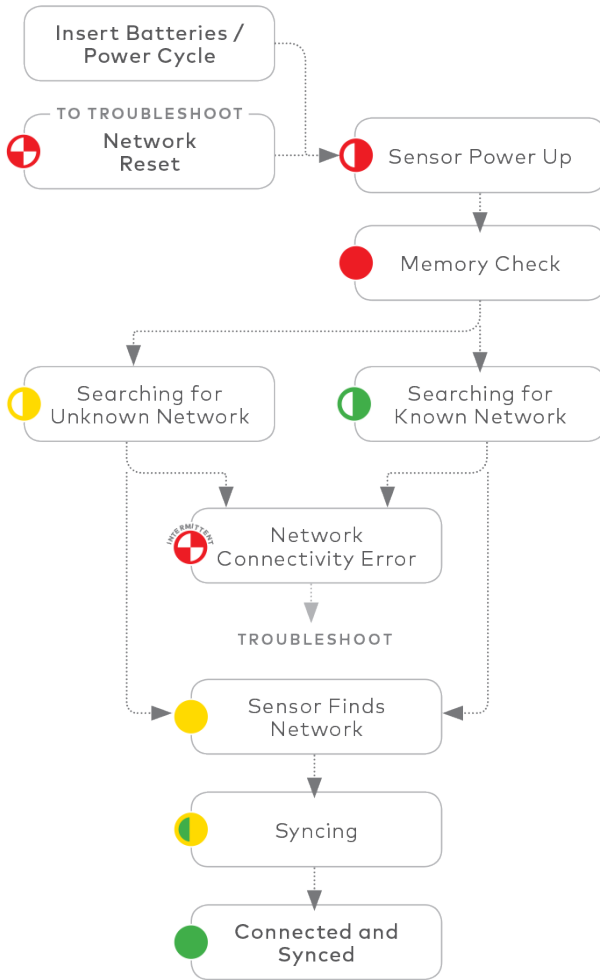

RESETTING THE IMAGE SENSOR

There are two ways to reset the Image Sensor:

- **Power Cycle** – Power Cycle can be done by one of two ways: (1) Take out and reinsert batteries or (2) press and release the sensor reset button. Only initiate a power cycle if the LED has not been active in the last 10 seconds. After a power cycle, the Image Sensor will enter sensor power up state followed by the memory check state.
- **Network Reset** - An Image Sensor must be network reset when it has been previously enrolled on a different panel. The Image Sensor will indicate that it is enrolled on a panel by blinking green after the memory check. In order to perform a network reset, press and hold the reset button for a full 10 seconds or until the red LED flashes rapidly. Release as soon as you see the rapidly flashing red LED. A successful network reset will result in the LED blinking



yellow after the memory check (solid red LED).

A network reset will only work if the Image Sensor is not actively communicating with a network. If the Image Sensor is within range of the original panel, it is required that the Image Sensor first be deleted from the panel it was previously learned into before being able to perform a network reset on the Image Sensor. See instructions on how to properly delete the Image Sensor from the panel. After releasing the reset button, the Image Sensor will enter sensor power-up mode (blinking red LED) followed by memory check (solid red LED) followed by either a blinking green or blinking yellow light. See Camera LED Reference Chart for the full list of status indicators and expected behaviors.



PIR ACTIVATION & TEST MODE

By default, the image sensor LED does not illuminate when activated by motion unless the sensor is in test mode. The LED can be enabled by tampering the device, via the Alarm.com Partner Portal, or on the panel for each Image Sensor on a customer's account. The Image Sensor must have successfully completed the enrollment process with a panel. When enabled, the red LED illuminates for 3 seconds upon motion activations (at most every 3 minutes while disarmed).

Instructions to activate on the panel (Note: It may take up to 30 seconds for test mode to take effect after requesting "Test PIR" at the panel):

- **On the XTi panel**, enter the *Test* menu under *Image Sensor* and tap **PIR**. The screen will display a confirmation to indicate the test mode command has been sent.

Test mode cannot be activated from the Concord panel.

TAMPER & TROUBLE CONDITIONS

Tamper: A built-in accelerometer detects movement or re-positioning of the Image Sensor and will initiate a tamper whenever a change in sensor orientation is detected. The tamper automatically clears after the sensor is returned to the upright position and no movement has been detected for 5 minutes. A tamper can also be cleared by resetting the sensor.

Trouble Conditions: By default, trouble conditions (malfunction, tamper & low battery) are displayed on the panel LCD. Enable or disable trouble condition messages on the control panel LCD via the Alarm.com Partner Portal. Trouble conditions are always reported to the Alarm.com Customer Website and customers will receive tamper/low/malfunction notifications if they are subscribed, regardless of the panel setting.

SERVICE PACKAGES REQUIREMENTS

Image capture features require a service package that includes one of the following Image Sensor add-ons:

Images - Alarms- Includes upload of images from alarm events only.



Images - Plus- Includes upload of images from alarm events and non-alarm events

INSTALLATION: PREPARING PANEL FOR ENROLLMENT

1. **Create Alarm.com Customer Account** - Select service package (see [Service Package Requirements](#)) and register the Alarm.com module serial number on the Alarm.com Partner Portal.
2. **Install Image Sensor Daughterboard if necessary.** – To verify if a daughterboard is needed, see [Hardware Compatibility Requirements](#).
3. **Register Module and Test** - Power up the panel and initiate a comm-test to ensure the Alarm.com module is properly installed and communicating with Alarm.com.

INSTALLATION: ENROLLING IMAGE SENSOR TO PANEL

1. Put the panel into add mode.
 1. Go to the home screen.
 2. Tap **Settings**.
 3. Tap **Programming**.
 4. Enter the installer code.
 5. Tap **Interactive Services**.
 6. Tap **Image Sensor**.
 7. Tap **Add**.
 8. The screen will display *Reset or power-up sensor to enroll...*
2. Insert the batteries into the Image Sensor. The LED on the Image Sensor will progress from blinking red to solid red to blinking yellow. This indicates the Image Sensor is in learn mode.
3. Wait approximately 20 seconds for the Image Sensor to enroll to the panel. The screen on the panel will display the following: *I.S. [x] Added as Sensor [y]*. The LED on the Image Sensor will turn solid yellow indicating that it has successfully found the panel.
4. After the Image Sensor LED has turned solid yellow, you must exit Add Mode on the panel. The Image Sensor LED will alternate between green and yellow while the customer's device list is updated with Alarm.com. The LED will turn solid green when the Image Sensor has been successfully added to the customer's account. Note: If you move (tamper) the Image Sensor after the LED has turned solid green, the Image Sensor will enter test mode for 3 minutes indicated by red LED when motion is detected. You may continue with the mounting portion of the installation when in test mode. See the Image Sensor LED Reference Chart for more details.

The sensor is now learned into the panel. Sensors are enrolled in group 17 by default. To change the sensor group, use the Sensors menu in Programming. Image Sensors may be enrolled in groups 15, 17, or 25. (No chime issued for group 25)

Note: Alarm.com does not recommend using sensor group 20 for Image Sensor Installations.

After enrollment, be sure to keep the sensor and panel powered so the sensor can complete an initialization process with the Alarm.com Network Operations Center. This process will take several minutes. Images cannot be captured until initialization is complete. Check by verifying if the rules are confirmed on the Partner Portal or MobileTech.



INSTALLATION: MOUNTING IMAGE SENSOR

1. Determine the desired mounting angle – 3 options

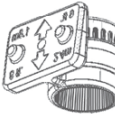
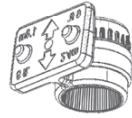
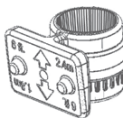
INTENDED OPERATION	Pet Immunity	Larger Rooms	Smaller Rooms
MOUNTING HEIGHT	6 Feet	8 Feet	8 Feet
ANGLE	Shallow, 6°	Shallow, 6°	Deep, 18°
BRACKET ORIENTATION	Teeth Up 	Teeth Up 	Teeth Down 
COVERAGE DISTANCE	30 to 35 ft.	30 to 35 ft.	15 to 20 ft.

2. Screw bracket to backplate.

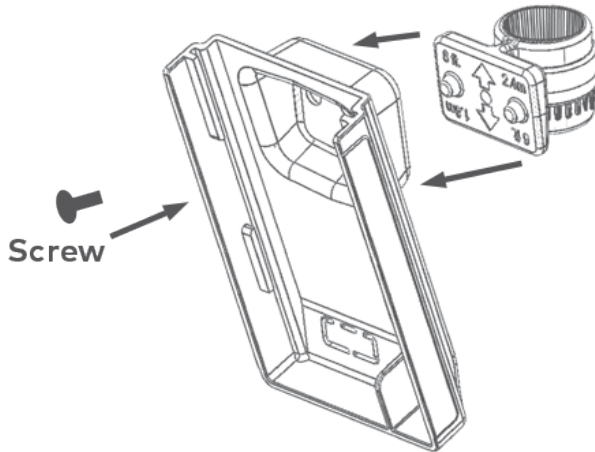

3. Determine location to mount sensor.

**Best Practices for Installing Image Sensor:
Do's and Don'ts**

 **DO:**

- Center the target capture area in the middle of the frame.
- Enroll and install within 100 ft. of panel. Installation site conditions can reduce range considerably.
- Make sure people will walk across the sensor coverage area instead of directly toward the sensor.
- Avoid backlit conditions (for example, facing a window or other light source) because it may result in poor image quality.

 **DON'T:**

- Set sensor on a flat surface.
- Set sensor across from mirrors or reflective surfaces.
- Face sensor toward or close to areas that have metallic objects or electronics (to avoid interference with RF communication).
- Install in an area where there are obstructions in front of or around the camera lens (for example, walls and ceilings within 90 degrees and 2 ft. around the camera). This type of installation will result in washed out night captures.
- Install outdoors.
Sensor is for indoor use only.

4. Choose applicable mounting bracket. The sensor hardware packet contains two mounting brackets for different mounting scenarios. Use the provided large screws and anchors to attach the bracket to the wall. (Leave at least 3 inches of clearance above the sensor to allow for battery replacement without uninstalling



the mounting bracket.)



Flat Wall Mount

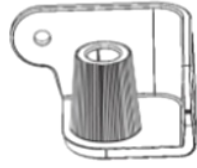

Corner Wall Mount

5. Place sensor with arm on mounting bracket. Adjust the horizontal positioning of the sensor to point towards the desired coverage area.
6. Secure the mounting arm location by sliding lock pin into the hole. Use the washer and remaining small screw to secure the lock pin by screwing upwards through the bottom of the hole in the mounting bracket.

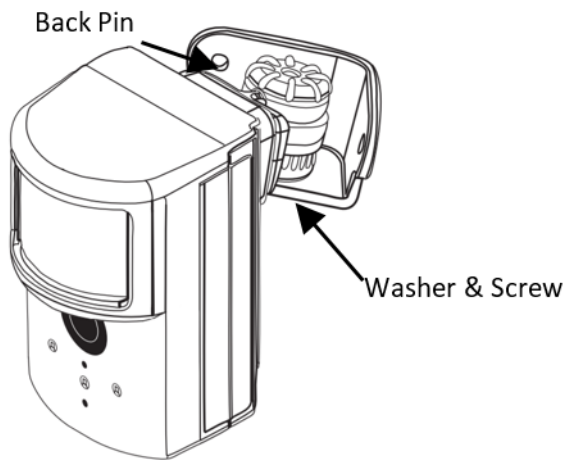

7. Set PIR Sensitivity Settings – 3 options that can be set through the panel or on the Partner Portal:

PIR Sensitivity Settings Table	
NORMAL	Default setting
HIGH	More sensitive motion profile with potential higher risk of false alarm.
LOW	Less sensitive profile with pet immunity for pets up to 40 lbs.

8. Verify and Test Image Sensor Setup



- a. Verify that rules are confirmed via the Partner Portal or on MobileTech, Resend rules if they are not confirmed.
- b. Verify RF Coverage by checking that the signal strength is above 40%. The signal strength must be greater than 30% for sensor to function properly.
- c. Conduct walk test - To conserve the customer's monthly image upload quota, automatic alarm uploads are disabled for the first four hours after any new sensor (Image Sensor or other) is installed into the system. Installers can also test by requesting image uploads and motion image uploads via MobileTech. Installers are required to be onsite to test by running a comm test at the panel.
- d. Test night captures.

DELETING IMAGE SENSOR FROM PANEL

It is important to follow these steps in order.

Delete the Image Sensor from the account using the panel's Interactive Services, Partner Portal or MobileTech.

Perform a network reset of the Image Sensor. See instructions on how to network reset an Image Sensor. You will only be able to do this after you've completed step 1 or if the Image Sensor is out of range of its current network.

PIR Lens and Camera Coverage Diagrams

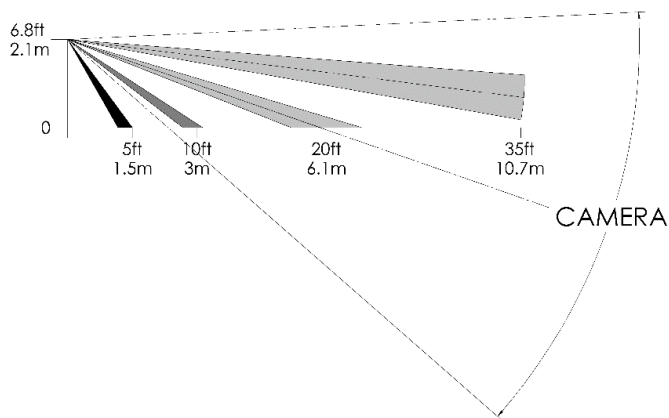

Figure 3.Side View: PIR Lens Coverage



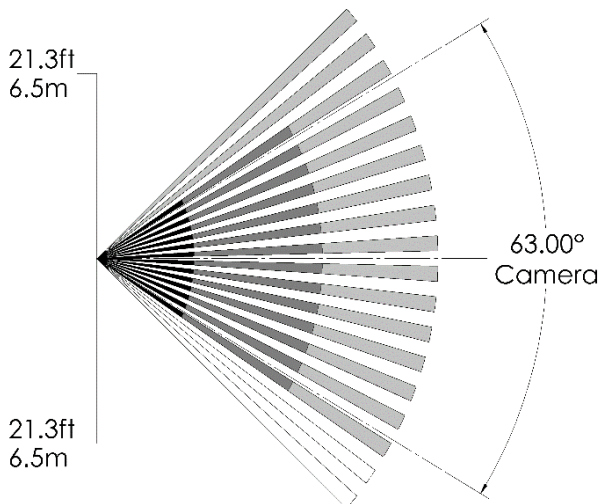

Figure 4. Top View: PIR Lens Coverage

As indicated in Figure 4, the camera coverage area is narrower than the PIR coverage area. When installing, mount sensor where subjects are likely to be centered in or across PIR and camera field of view.

TROUBLESHOOTING

General Troubleshooting Steps

- Verify Module Signal Strength
- Verify Image Sensor RF Signal Strength: The signal strength must be above 30% for the sensor to function properly.
- Verify Images service package: Image capture functionality depends on the customer's service package. Be sure the proper Image Sensor service package is selected.

Enrollment

- Verify Sensor is Receiving Power: After inserting batteries, the sensor LED should illuminate or flash within 10 seconds.
- Verify Sensor is Not Communicating with Another Network: If the sensor has been previously enrolled in a different system or daughterboard, delete the sensor from the system and hold the sensor reset button for 10 seconds to clear the sensor from old network before attempting to enroll the sensor in a new network. The sensor cannot be cleared if it is currently communicating with its network. In this case the sensor must be deleted from the system first through the control panel or remote command.



Sensor Non-Responsive

- **Verify Range:** Under the “Image Sensor Setup” menu, scroll to “Image Sensor Settings,” select the sensor and verify under “Signal” that the sensor is registering a strong signal. If signal strength is low, move non-responsive sensor closer to control panel, verify signal strength and see if communication resumes. Be sure that Image Sensor daughterboard antenna is correctly routed as indicated in step 5 of the installation procedure.
- **Replace Batteries:** Check battery level at the panel (under “Image Sensor Settings”) and install fresh sensor batteries.

Images Not Captured

- **Verify Sensor Rules:** Make sure the sensor initialization process has been completed. On the Partner Portal, verify rules have been confirmed using the “Rules Confirmed” column. If not, resend Image Sensor rules.
- **Enable Auto Uploads:** During the first four hours after any sensor is enrolled onto the system, alarm images will not automatically be uploaded to Alarm.com. Automatic uploads are automatically enabled after four hours. Enable uploads sooner from the Partner Portal.

False Motion Activations

- **Check Environmental Elements:** Heating or cooling elements may adversely affect sensor performance. Test sensor with and without these elements to determine interference. Check if there are any reflective surfaces facing the device (e.g. mirror).
- **Check Sensor Positioning:** The sensor may not be properly positioned to capture the desired motion. Check horizontal positioning of sensor and re-mount as necessary.
- **Check PIR Sensitivity Setting:** Verify that the proper sensor motion profile has been selected through the setup menu or select a less sensitive profile.

