



The **IQ Hardwire 16-S** offers a cost effective way of integrating hardwired security zones with the IQ Panel. It includes backup battery charging, an onboard siren relay and features end-of-line resistor learning, making rewiring different resistor values a thing of the past. It also supports magnetic contacts and powered zones such as motion sensors and glass break detectors. *Note: Not for use with life safety devices, such as Smoke or CO detectors*

IN THE BOX



IQ Hardwire 16-S
Cover
Antenna
Power Supply
4 Screws
16 Resistors (3K)
Battery cables

TECHNICAL SPECIFICATIONS

Input Voltage: 16.0VDC Plug-In Transformer
Backup Battery: 12VDC 5AH Max (optional)
Dimensions: 5.5" X 3.5"
Operating Temperature: 32 to 122F (0 to 50C)
Humidity: 95% RH Max
EOL Supervision: 1K to 10K Ohm
Input Zones: 16 (must have resistor)
Zone Type: N/O or N/C compatible
Auxiliary Voltage Output: 12VDC @ 500mA
Tamper Zone: Optional zone input for tamper
Relay Contact: 60VDC/1A Max drives siren or other device

INFORMATION

Document #: IQHW16SQG
Revision Date: 7/31/17
Qolsys Part #: QS7131-840



Confidential & Proprietary.
Made in Taiwan.
Full installation manual and other documentation available at Qolsys.com.

STEP 1: INSTALL THE HARDWARE

1. Mount the IQ Hardwire 16-S vertically in your desired location.
2. Install provided antenna into the "ANT" terminal at the top of the unit free from obstructions
3. Wire all hardwired sensors/leads into the terminals marked "Zone 1-16"
 - a. All sensors must have a resistor installed between 1k-10k Ohm in either the N/O or N/C position
 - b. Wire the Positive and Negative leads from powered devices, such as motion sensors and glass break sensors, into the "AUX" (+) and "GND" (-) terminals to power the device. (see wiring diagram)
 - c. Wire the tamper switch into the tamper terminals. (optional)
 - d. Wire optional hardwired siren (60VDC/1A Max, see wiring diagram)
4. If learning the IQ Hardwire 16-S into the Panel for supervision, plug in a 5Ah Max backup battery with included battery leads (battery not included).
5. With provided transformer, connect power supply leads into the terminals marked +16.0V GND then plug in the IQ Hardwire 16-S power supply. (IMPORTANT: dashed wire is positive)



If mounting inside a metal can, the antenna must extend outside the enclosure to ensure RF communication

STEP 2: PAIR THE IQ HARDWIRE 16 WITH THE IQ PANEL

Note: This allows the IQ Panel to supervise the IQ Hardwire battery, power status, aux power out, & tamper



Place your panel in "auto learn" mode



Press and hold "EOL Learn" for 1-2 secs. (all Zone LED's flash and then turn off)



EOL Cal LED will turn ON. This puts the module into "Enroll Mode"



Trip the module by "shorting" the "Tamper" terminals on the module with a piece of wire.



Follow the onscreen prompts on the IQ Panel to finish the enrolling process. The IQ Hardwire 16-S should be learned in as a "Hardwire Translator"

STEP 3: PAIRING INDIVIDUAL ZONES/SENSORS

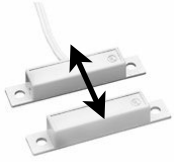

Trip (Open/Close) each hardwired zone one at a time



The IQ Panel will “chime” indicating it has found a new sensor. Touch “Okay” to proceed.



Customize sensor type and settings as desired. Repeat for each zone.

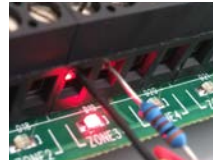

When a sensor has been tripped, the resistor value is calibrated and the Zone LED will illuminate and stay on until you exit enroll mode.



Once all desired zones have been learned, press the “EOL Learn” button to exit “Enroll Mode”. The EOL Cal LED will turn OFF indicating you are no longer in “Enroll Mode” and all zone LEDs will turn OFF.

TROUBLESHOOTING

EOL LEARN Button: To enter and exit “Enroll Mode” and calibrate resistor values

MEMORY RESET Button: Clears memory and resets the device to factory defaults

PROCESSOR LED: Flashes during normal operation

RF XMIT LED: Flashes when RF transmission is being sent

EOL CAL LED: Flashes when EOL resistors are not calibrated or when no zones have been learned. ON when device is in “Enroll Mode”. OFF when device is in “Normal Operation Mode”

ZONE LED: Flashes several times when EOL Cal button is pressed. OFF while in “Enroll Mode” unless a zone has been learned in or tripped, then ON. OFF while in “Normal Operation Mode” unless a zone is open, then ON.

How to Clear the Memory: Power down the unit by unplugging the battery leads and the power supply. Hold down “Memory Reset” for 3 seconds while re-applying power to the device. Processor, RF Xmit and EOL Cal LED’s will begin to flash indicating that the module has been reset.

WIRING DIAGRAM

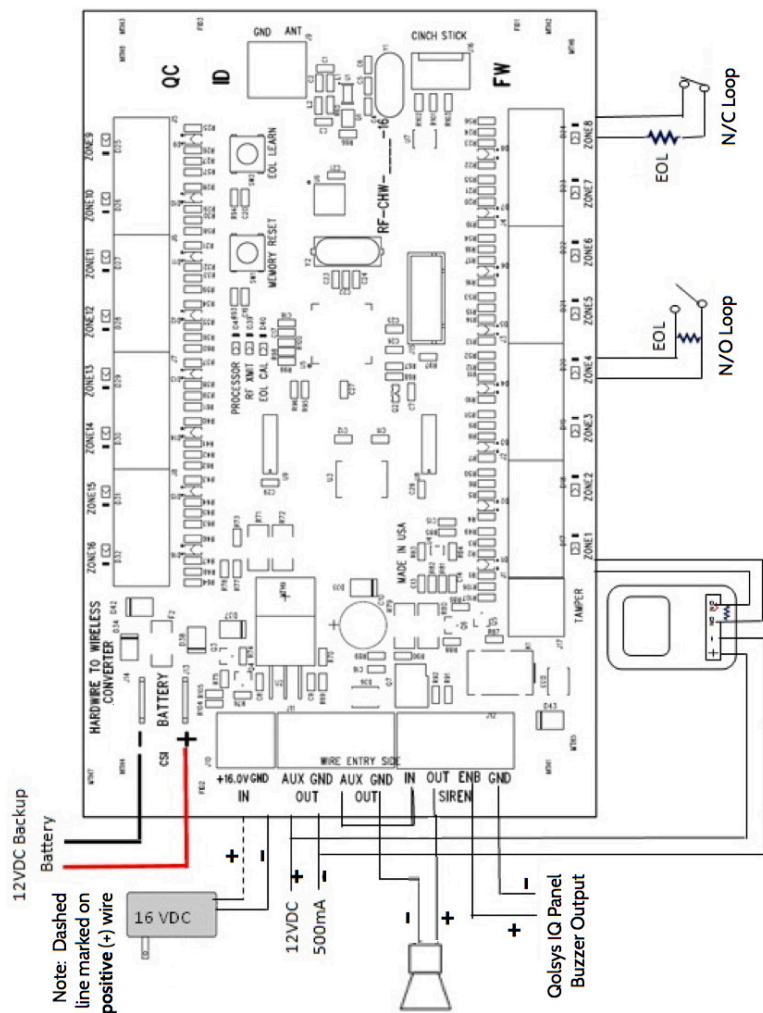

NEED MORE HELP?

CONTACT TECH SUPPORT
(855) 4-QOLSYS
TechSupport@Qolsys.com